

*High Efficiency
Compressed Air Filters*



Technical Specification

Technical information below refers to nominal operating condition of 8 barg at 20°C.
Maximum operating condition: Inlet air pressure at 16 barg, inlet air temperature at 80°C

Filter Model	Connection [BSP-F]	Flow Rate		Replacement Element [Model]	Dimensions [mm]				Weight [kg]
		[m ³ /min]	[scfm]		A	B	C	D	
FP12*	½"	1.53	54	E12	87	212	60	21	1.10
FP18*	¾"	2.43	86	E18	87	272	80	21	1.40
FP30*	1"	3.99	141	E30	126	288	100	34	2.90
FP80*	1 ½"	10.34	365	E80	126	480	140	34	4.00
FP105*	2"	15.07	532	E105	166	575	150	50	8.80
FP150*	2"	20.16	712	E150	166	710	200	50	10.4
FP200*	2 ½"	29.44	1040	E200	166	950	300	50	13.5
FP306*	3"	51.98	1826	E306	240	995	780	60	20.4

X1 = [1 Micron] **XA** = [0.01 Micron] **XAC** = [Activated Carbon]

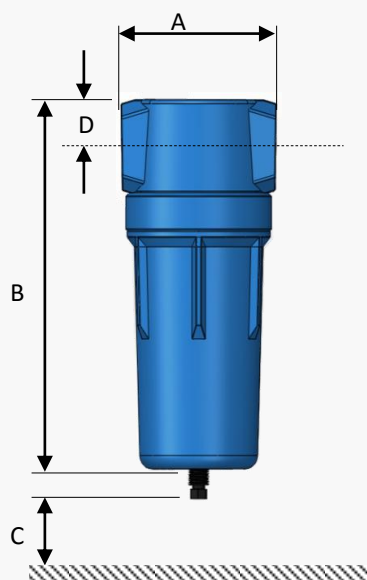

Grade	Description
X1 1 Micron	Filters for general purpose protection, capable of removing contaminants down to 1 micron, with oil residual present at 0.1 mg/m ³ .
XA 0.01 Micron	High efficiency coalescing filter, removing oil and water aerosol down to 0.01 mg/m ³ and extremely small particles to 0.01 micron.
XAC Activated Carbon	High efficiency activated carbon filter for removal of oil vapours and odours. It lowers to a maximum remaining oil residual of 0.003 mg/m ³ when installed after (XA) grade filter.

Correction Factor For Operating Pressure Changes

Inlet Air Pressure [bar g]	2	3	4	5	6	7	8	9	10	11	12	13	14	15	16
Factor	0.25	0.38	0.5	0.65	0.75	0.88	1	1.13	1.25	1.38	1.5	1.63	1.75	1.88	2

We reserves the right to alter any specification and technical data without prior notice.

